

19" ERATline 500-I Safebox Indoor IP55 Cabinets Accessories

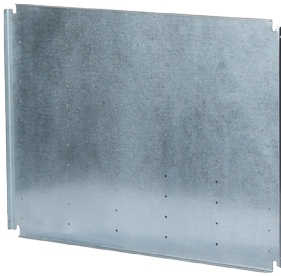

Fan Module with Analog Thermostat Switch - 220 V AC

Product Model	Dimensions WxDxH mm	Description
Accessory	495x175x50	Single fan module with analog thermostat switch, filtered
Accessory	495x175x50	Double fan module with analog thermostat switch, filtered



Mounting Plates for ERATline 500 Safebox Cabinets

Product Model	Dimensions WxDxH mm	Description
Accessory	t: 1 mm H:350 mm W:575 mm	7U Mounting Plate- Galvanized
Accessory	t: 1 mm H:400 mm W:575 mm	9U Mounting Plate- Galvanized
Accessory	t: 1 mm H:570 mm W:575 mm	12U Mounting Plate- Galvanized
Accessory	t: 1 mm H:748 mm W:575 mm	16U Mounting Plate- Galvanized

To be mounted on the internal surface of the rear panel of the cabinet. Allows industrial components, electrical components and DIN rails mounting.

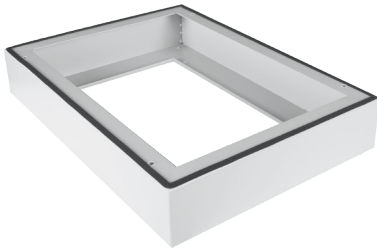

Floor Mounting Applications

Product Model	Dimensions WxDxH mm	Description
Accessory	600x300x100	Plinth H:100 mm W:600 x D300 RAL 7035 Light Grey
Accessory	600x450x100	Plinth H:100 mm W:600 x D450 RAL 7035 Light Grey
Accessory	600x600x100	Plinth H:100 mm W:600 x D600 RAL 7035 Light Grey

19" ERATline 500-I Safebox Indoor IP55 Cabinets

Width: 600 mm
Depth: 300/450/600 mm



Production Standards:

- ISO 9001:2015 - Quality Management System
- ISO 14001:2015 - Environmental Management System

Compliance:

- EN 61587-1 Mechanical structures for electronic equipment - Tests for IEC 60917 and IEC 60297 series
- Climatic and Environment: EN 61587-1/4.2, IEC60068-2-1, IEC60068-2-2, IEC60068-2-30
- Static Mechanical Load Lifting: EN 61587-1/5.2.1
- Static Mechanical Load Stiffness: EN 61587-1/5.2.2
- Dynamic Mechanical Load Vibration and Shock, Impact: EN61587-1/5.3.1, EN61587-1/5.3.3, IEC60068-2-6, IEC60068-2-27
- Earth Bond: EN61587-1/6.2
- Flammability: EN 61587-1/6.3
- Degrees of Protection Provided by Enclosures (Ip Code): IP55
- EN 13501-1+ A1- Epoxy Powder coated compliant to Fire classification of construction products and building elements Part 1: Classification using data from reaction to fire tests
- Epoxy Powder coating tested as per EN ISO 9227 and ASTM B 117 Corrosion tests in artificial atmospheres - Salt spray tests; minimum 1000 hours
- EN ISO 2409 Paints and varnishes - Cross-cut test
- EN ISO 2178 Non-magnetic coatings on magnetic substrates
- Measurement of coating thickness - Magnetic method
- RoHS Compliancy according to 2011/65/EU
- CE Compliant to EN 60950-1



Wall mounted maximum load capacity up to 300 kg.



ERATline 500-I Series Safebox Indoor IP55 Cabinets 7U/9U/12U/16U W600 x D300/450/600 mm

- Mono-block welded construction, coated with polyester type powder, on RAL 7035 - Light Grey.
- 7U - 9U have one key-locking quarter-turn wing knob, 12U - 16U have two key-locking quarter-turn wing knobs, 1 set of 19" front equipment mounting rails.
- 4 x PG21 cable entries blind plugs.
- The safebox has one filtered air inlet and a filtered passive ventilation and hot air exhaust. Where required the filterers can be replaced with an exhaust fan or an exhaust fan with thermostat (optional accessories).
- Wall mounting brackets and grounding cable are included.
- The metallic door has polyurethane sealing gasket compatible with EN 60529 IP54/IP55 code protection. IP code can be upgraded up to IP66 by replacing the fan ventilation slots with cover plates.
- The maximum load capacity is up to 300 kg as a wall mounted and up to 800 kg as a free standing.
- Safebox can be floor mounted when using a plinth.
- An optional rear mounting plate can be used to host industrial or electrical equipment that can not be mounted on 19" rails (optional).

19" ERATline 500-I Safebox Indoor IP55 Cabinets

Width: 600 mm

Depth: 300/450/600 mm

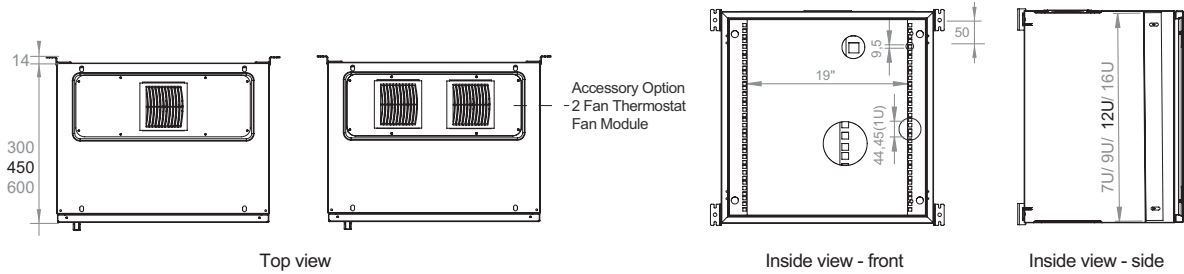
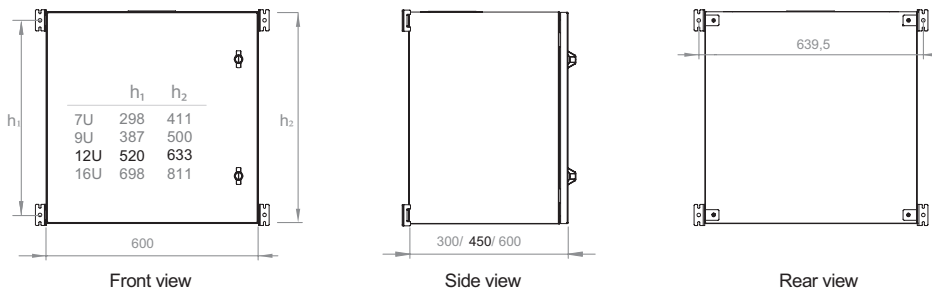
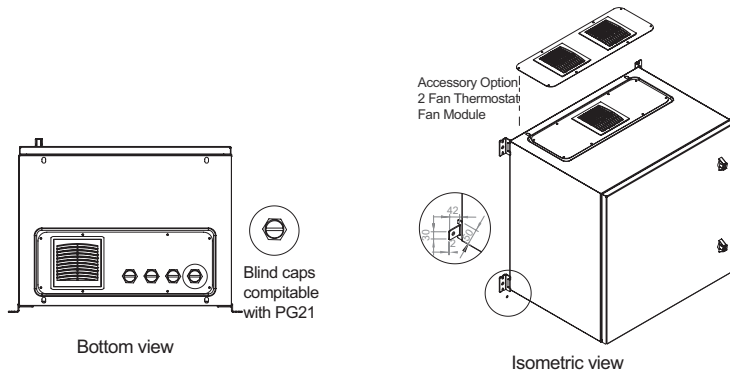

19" ERATline 500-I Safebox Indoor IP55 W600 x D300 mm Cabinets		
Dimensions WxDxH mm	Package Size WxDxH mm	Product Description
600x300x411	650x350x429	7U 19" W600 x D300 mm Indoor IP55 Cabinet
600x300x500	650x350x516	9U 19" W600 x D300 mm Indoor IP55 Cabinet
600x300x633	650x350x651	12U 19" W600 x D300 mm Indoor IP55 Cabinet
600x300x811	600x350x829	16U 19" W600 x D300 mm Indoor IP55 Cabinet

19" ERATline 500-I Safebox Indoor IP55 W600 x D450 mm Cabinets		
Dimensions WxDxH mm	Package Size WxDxH mm	Product Description
600x450x411	650x500x429	7U 19" W600 x D450 mm Indoor IP55 Cabinet
600x450x500	650x500x516	9U 19" W600 x D450 mm Indoor IP55 Cabinet
600x450x633	650x500x651	12U 19" W600 x D450 mm Indoor IP55 Cabinet
600x450x811	600x500x829	16U 19" W600 x D450 mm Indoor IP55 Cabinet

19" ERATline 500-I Safebox Indoor IP55 W600 x D600 mm Cabinets		
Dimensions WxDxH mm	Package Size WxDxH mm	Product Description
600x600x411	650x650x429	7U 19" W600 x D600 mm Indoor IP55 Cabinet
600x600x500	650x650x516	9U 19" W600 x D600 mm Indoor IP55 Cabinet
600x600x633	650x650x651	12U 19" W600 x D600 mm Indoor IP55 Cabinet
600x600x811	600x650x829	16U 19" W600 x D600 mm Indoor IP55 Cabinet