

19" ERATline 300 Series

Free Standing Cabinets Accessories



Fan Modules for wall mounting cabinets, plug and play without reconfiguration, available with on/off switches or automatic analog thermostat . Each fan has an air flow capacity of 2,3-3 cbm/min. Fan technical data: 18/17 W, 220/240 VAC, 50/60 Hz, 013/0,11 A,2300/3000 rpm 42 dB noise level, Fan lifetime span: 50.000 hours.



| Fan Module On/Off Switched Ball Bearing Long Life Fan - 50.000 Hours - Features | |
|---|---|
| Category | Product Description |
| Accessory | 1 fan module on/off switched wall mounting type |
| Accessory | 2 fan module on/off switched wall mounting type |

| Fan Module Thermostat Switched Ball Bearing Long Life Fan 50.000 Hours - Features | |
|---|---|
| Category | Product Description |
| Accessory | 1 fan module thermostat switched wall mounting type |
| Accessory | 2 fan module thermostat switched wall mounting type |

*CC= Color codification. Replace CC with BL for Black RAL 9005 Color and replace CC with LC for Light Grey RAL 7035 Color.

| Fan Module On/Off Switched Ball Bearing Long Life Fan 50.000 Hours - Economic - Features | |
|--|----------------------------------|
| Category | Product Description |
| Accessory | 1 way fan module on/off switched |
| Accessory | 2 way fan module on/off switched |

| Fan Module Thermostat Switched Ball Bearing Long Life Fan 50.000 Hours - Economic - Features | |
|--|--|
| Category | Product Description |
| Accessory | 1 way fan module thermostat controlled |
| Accessory | 2 way fan module thermostat controlled |

*CC= Color codification. Replace CC with BL for Black RAL 9005 Color and replace CC with LC for Light Grey RAL 7035 Color.

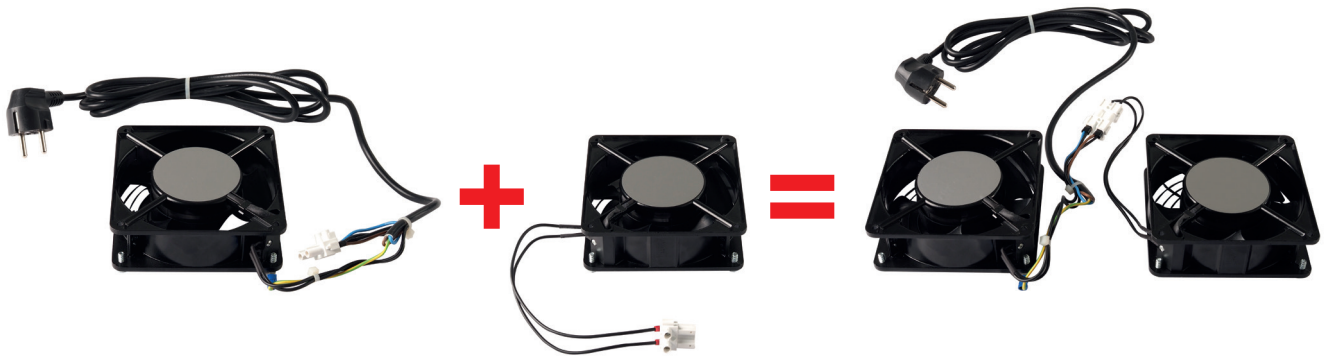

| Economic Extendable Fan Modules - No any Metal Housing - Ball Bearing Long Life Fan- 50.000 Hours - Economic+ | |
|---|---|
| Category | Product Description |
| Accessory | Single fan with grill 1,8 meter power cable DIN49441 Schuko Plug and extension terminal male ball bearing long life fan |
| Accessory | Single fan with grill extension terminal female ball bearing long life fan |

* LN-FAN-HL-1FBB-E is just a fan for making cabinet equipped with 2 fans used with main product LN-FAN-HL-1FBB-M and add the extension fan.

19" ERATline 300 Series

Free Standing Cabinets

Width: 600 mm

Depth: 600/800 mm



Production Standards:

- ISO 9001:2015 - Quality Management System
- ISO 14001:2015 - Environmental Management System

Compliance:

- EN 61587-1 Mechanical structures for electronic equipment - Tests for IEC 60917 and IEC 60297 series
- Climatic and Environment: EN 61587-1/4.2, IEC60068-2-1, IEC60068-2-2, IEC60068-2-30
- Static Mechanical Load Lifting: EN 61587-1/5.2.1
- Static Mechanical Load Stiffness: EN 61587-1/5.2.2
- Dynamic Mechanical Load Vibration and Shock, Impact: EN61587-1/5.3.1, EN61587-1/5.3.3, IEC60068-2-6, IEC60068-2-27
- Earth Bond: EN61587-1/6.2
- Flammability: EN 61587-1/6.3
- Degrees of Protection Provided by Enclosures (Ip Code): IP20
- EN 13501-1+ A1- Epoxy Powder coated compliant to Fire classification of construction products and building elements Part 1: Classification using data from reaction to fire tests
- Epoxy Powder coating tested as per EN ISO 9227 and ASTM B 117 Corrosion tests in artificial atmospheres - Salt spray tests; minimum 1000 hours
- EN ISO 2409 Paints and varnishes - Cross-cut test
- EN ISO 2178 Non-magnetic coatings on magnetic substrates
- Measurement of coating thickness - Magnetic method
- RoHS Compliancy according to 2011/65/EU
- CE Compliant to EN 60950-1



Maximum load capacity up to 600 kg.



Free Standing ERATline 300 Series Cabinets

12U/16U/20U/22U W600xD600 mm and W600xD800 mm

- Multi folded modular design clamped with screws, coted with RAL 9005 epoxy polyester powder.
- Single point barrel locking glass front door and metal rear door. Removable side panels are lockable.
- 1 set of 19" front depth adjustable equipment mounting rails & 1 set of 19" rear fixed equipment mounting rails, U height numbered.
- Two 70x140mm PVC and brushed cable entrances located at the top and bottom of the cabinet, swappable during the field applications.
- Ventilation slots that can mount single or double fan modules for forced ventilation.
- Front glass door is covered by EN 12150-1 standard with 4,0 mm thick anti-static tinted smoke tempered glass and metal frame.
- Maximum load capacity up to 600 kg.
- 4 adjustable feet group included, replaceable by a castor set (optional).

19" ERATline 300 Series

Free Standing Cabinets

Width: 600 mm

Depth: 600/800 mm

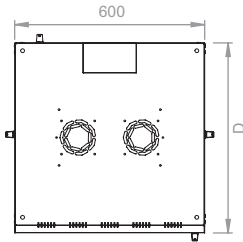

Top view

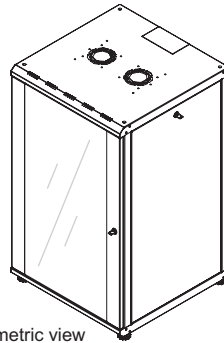

Isometric view

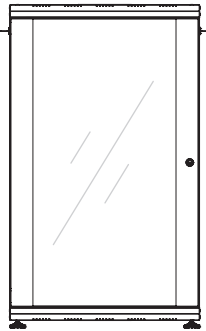

Front view

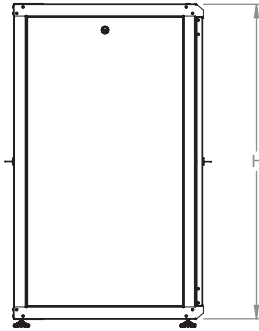

Side view

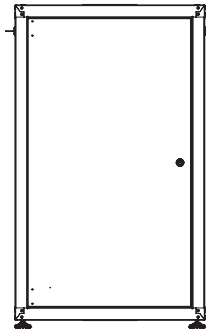

Rear view

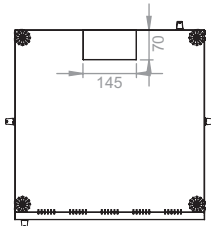

Bottom view

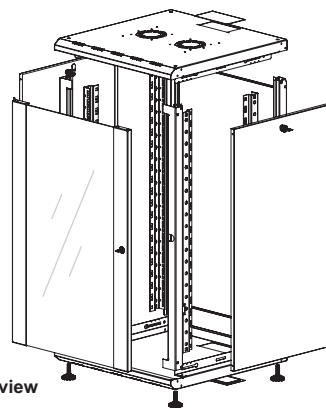

Exploded view



19" ERATline 300 Series Free Standing Cabinets W600 x D600 mm

| Dimensions WxDxH mm | Package Size WxDxH mm | Product Description |
|---------------------|-----------------------|--|
| 600x600x640 | 650x650x656 | 12U 19" W600 x D600 mm Free Standing Cabinet |
| 600x600x818 | 650x650x834 | 16U 19" W600 x D600 mm Free Standing Cabinet |
| 600x600x996 | 650x650x1012 | 20U 19" W600 x D600 mm Free Standing Cabinet |
| 600x600x1085 | 650x650x1101 | 22U 19" W600 x D600 mm Free Standing Cabinet |

19" ERATline 300 Series Free Standing Cabinets W600 x D800 mm

| Dimensions WxDxH mm | Package Size WxDxH mm | Product Description |
|---------------------|-----------------------|--|
| 600x800x640 | 650x850x656 | 12U 19" W600 x D800 mm Free Standing Cabinet |
| 600x800x818 | 650x850x834 | 16U 19" W600 x D800 mm Free Standing Cabinet |
| 600x800x996 | 650x850x1012 | 20U 19" W600 x D800 mm Free Standing Cabinet |
| 600x800x1085 | 650x850x1101 | 22U 19" W600 x D800 mm Free Standing Cabinet |

* H length can be checked from the product dimensions.